



GEL MATIC

THE TASTE OF QUALITY

MADE IN ITALY





presents



The Taste of Made in Italy.

Gel Matic Italia, a leading figure in the world of ice cream, specializes in express blending technology. Their success is the result of passion, a shared vision, and great dedication. With its strong local roots and professional relationships, Gel Matic is proud to have turned the "Made in Italy" label into a symbol of guaranteed quality for its international customers.



Gel Matic...from product maker to solution provider.

Each Gel Matic machine includes a full series of services and technologies that were developed to support customers and ensure correct use of the machine for long service life.



GTECH

Technological Excellence

The control systems, food contact areas, and production systems are designed to the highest possible standards of reliability, performance and durability.



GTECHHT

The GTECH Heat Treatment cycle sanitizes the mixture to minimize bacterial load. This reduces mix waste and helps extend time between cleanings.



GTECHECOS

Simple, multilingual LCD touch controls with five capacitive keys.



GTECHHEALTHY

Ensures the quality and safety of the product with mix storage status, Heat Treatment cycle execution and time recording, and ensures cleaning cycle frequency in compliance with expiration dates.



GTECHINCODIS 3.0

A large multilingual touchscreen display with tutorials and predictive technology to help improve machine performance.



GLEARN

Valued Relationships

A true market leader takes great care over each stage in the product process—including customer service.



GLEARNEDUTECH



GLEARN TUTORIAL



GLEARN SALES

A true market leader takes great care over each stage in the product process—including customer service. Three different areas of training help ensure users fully understand Gel Matic's philosophy, are able to operate the machines correctly, and can get the most out of their investment. Each member of the Gel Matic sales network has received technical training to help guarantee excellence.



GCARE

Ongoing Support

GCARE is a full package of service and support for Gel Matic machines. Ask about all the GCARE options available.



GCARECONNECT

A revolutionary service that lets you access your machine quickly and easily from a remote location using any device (smartphone, tablet, computer, etc.).



GCAREMAINTENANCE

Gel Matic values ensuring that operators use its machines correctly—both under normal operating conditions and in an emergency.

Standard Range

Versatility is key with these machines, capable of producing milk- or fruit-based gelato, soft serve, or frozen yogurt. Choose from countertop or floor-standing models with one or two flavor outputs. You can expect quality product every time, thanks to special beaters that achieve the perfect texture and creaminess customers crave. A top-load refrigerated storage hopper holds the liquid mixture at 39.2°F, while a mixer keeps it smooth and even. Enjoy easier cleaning and maintenance thanks to the gravity-fed system that passes the mixture (even with small pieces of fruit!) from the hopper to the cylinder.

COUNTERTOP

BC EASY 1 GR

One Flavor
18" w x 27 1/8" d x 32 3/8" h
Weight: 240 lb

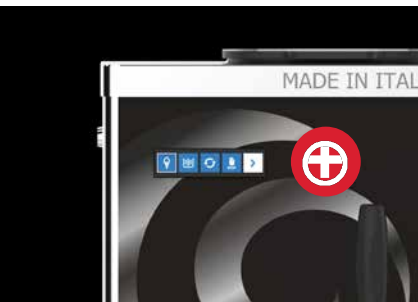

BC EASY 2 GR

Two Flavors + Twist
20 7/8" w x 30 1/2" d x 33 1/2" h
Weight: 450 lb



Versatility comes as standard



Specially Designed SF2 Beater

Designed for improved mixing during the blending and freezing phase, the shape has minimum impact to preserve the structure of your product.

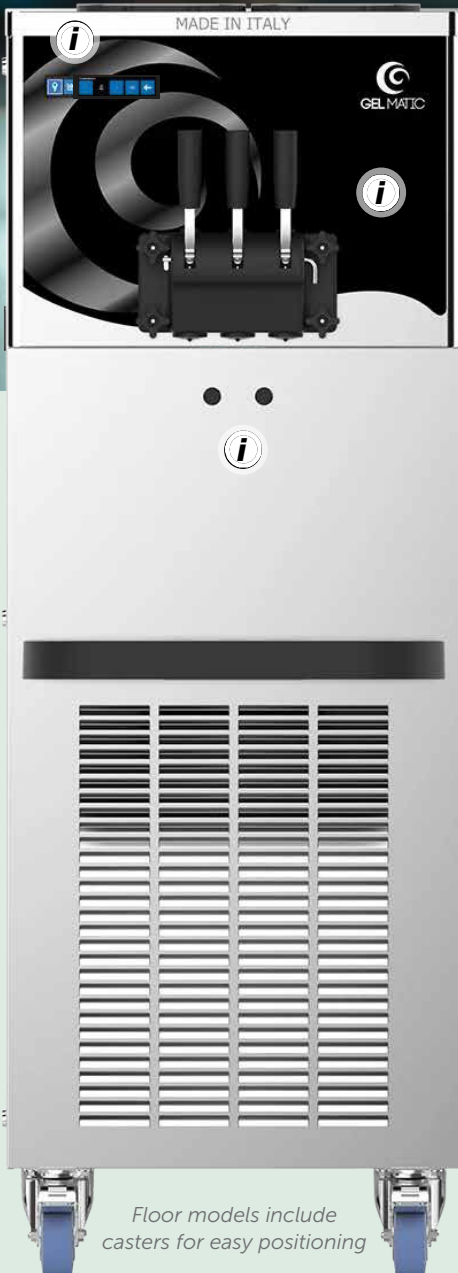

Floor models include casters for easy positioning

FLOOR

BV EASY 2 GR

Two Flavors + Twist
20 $\frac{1}{8}$ "w x 30 $\frac{1}{2}$ "d x 58 $\frac{3}{8}$ "h
Weight: 450 lb



Easy to Clean & Install

For maximum efficiency, regular service is required. Each machine comes with a kit to maintain optimum cleaning and sanitizing.

Giotto Range

Giotto range marks a new era for the world of ice cream machines. With a unique, upscale look and advanced functionality, these machines are the result of painstaking design work combined with Gel Matic technology. No detail has been overlooked, ensuring each machine is easy to use, guarantees excellent performance with accurate control, and minimizes downtime while extending the life of each component. All Giotto models are more than just a machine: they are a system built to empower the user at every stage in the production process.



COUNTERTOP

GIOTTO 11 GR

One Flavor
11¹³/₁₆"w x 27¹³/₁₆"d x 30¹¹/₁₆"h
Weight: 185 lb



Available in
Three
Eye-Catching
Colors



Easy to Clean, Use & Install

Video tutorials guide you through all the features for simple, hassle-free operation. GCARE Maintenance and Connect help you keep up with cleaning schedules, machine data, and more for safe & efficient operation.





State of the Art.

Giotto ushers in a new era for the world of ice cream machines.

AWB Beater

Designed for improved mixing during the blending and freezing phase, the shape has minimum impact to preserve the structure of your product.



COUNTERTOP

GIOTTO 12 GR

One Flavor
15¹¹/₁₆"w x 32"d x 34⁵/₈"h
Weight: 260 lb



Available in
Three
Eye-Catching
Colors

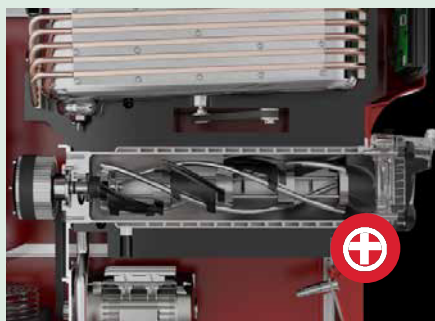



GIOTTO 21 PM 

Two Flavors + Twist
21¹/₁₆"w x 30⁷/₁₆"d x 30¹⁴/₁₆"h
Weight: 295 lb



Available in
Three
Eye-Catching
Colors

COUNTERTOP



Frozen Beverages

Offer with an unlimited variety of frozen beverages, including cocktails and shakes with mix-ins.



GIOTTO DR 14 GR

One Flavor
16⁷/₈"w x 27³/₁₆"d x 30¹/₁₆"h
Weight: 220 lb



Specially Designed AWB Beater

Designed for improved mixing during the blending and freezing phase, the shape has minimum impact to preserve the structure of your product



COUNTERTOP

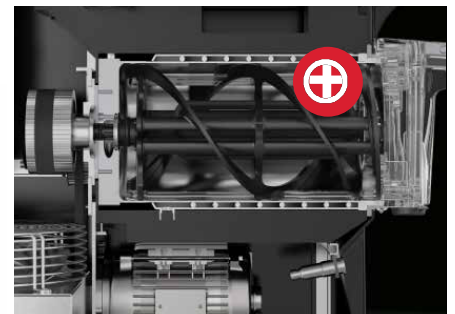



180 Broad Street, Clifton, New Jersey 07013
Sales (973) 574-3150 | Service (973) 574-3670

sales@europeangourmetimports.com